

CLEVIS PINS

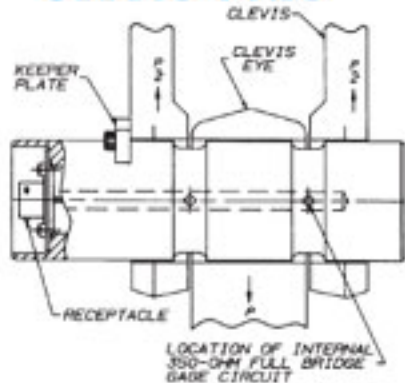

- Winch/Crane/Lifting Systems
- Aircraft Wing Joints
- Landing Gear Clevis Joints
- Hydraulic Cylinders
- Sprocket, Pulley Axles
- Conveyors
- Mooring Lines
- Nuclear Fuel Rod

FLAT LOAD CELLS®

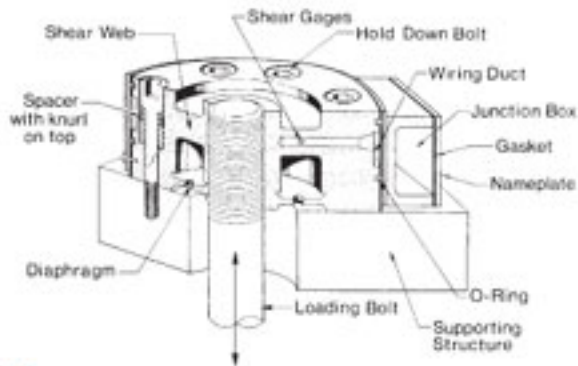

- Bin Weighing
- Process Control Systems
- Hydrostatic
- High Load Fatigue Tests
- Test Standards
- Hoist/Crane

BOLTS & STUDS

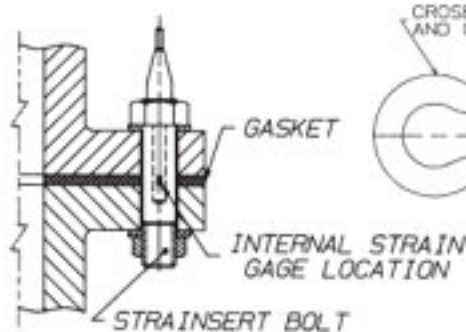

- Critical Bolted Attachments
- Interstage Attachments
- Payload Forces
- Antenna Joints
- Aircraft Tire Hubs
- Engine Attachments
- Aircraft Flanges

TENSION LINKS

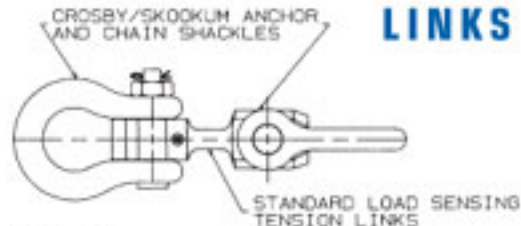

- Line Tensioning
- Mooring/Tow
- Hydrostatic/Undersea
- Test Standards
- Hoist/Crane