

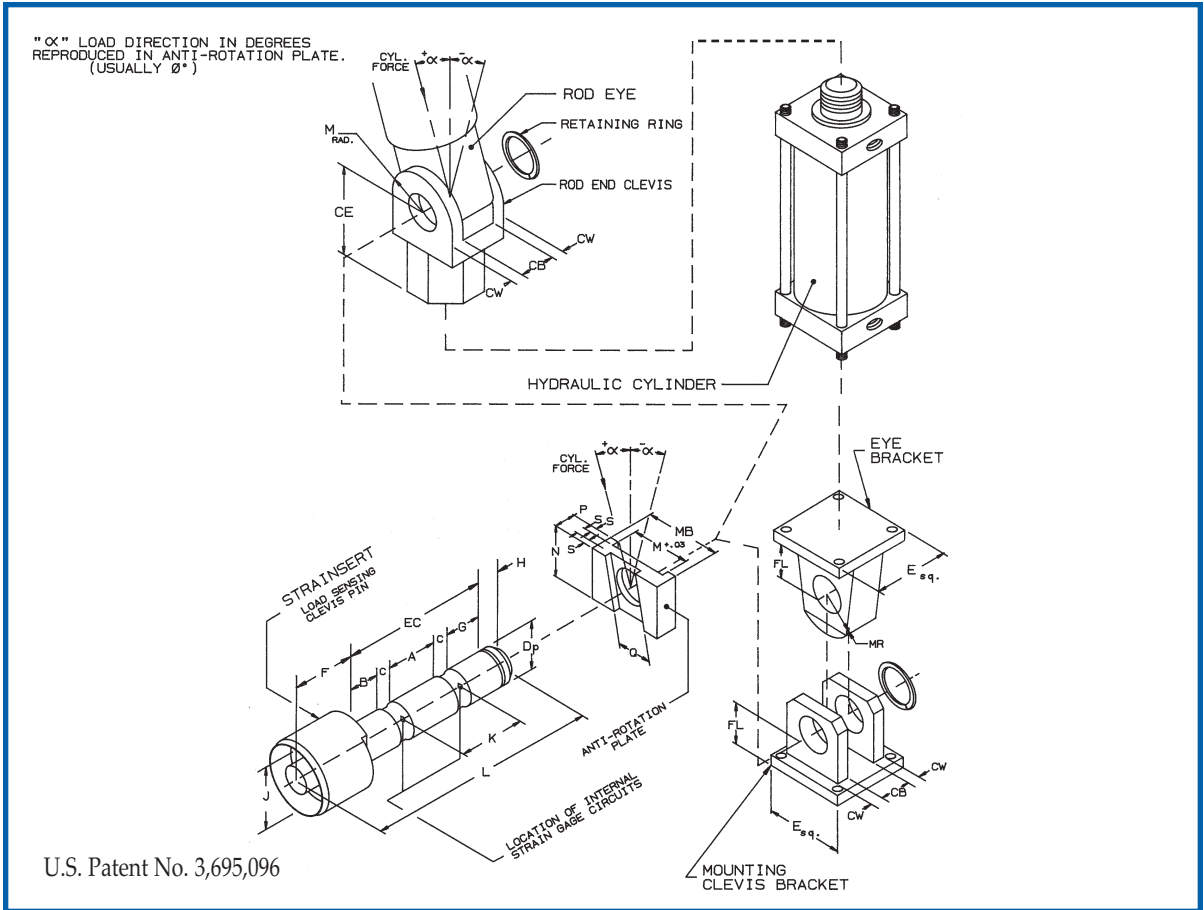

SPHC Series, Standard Force Sensing Clevis Pins

(For Hydraulic Cylinders)



CLEVIS PIN NOMENCLATURE

A	Width of Center Loading Section	H	Allowance for Retaining Ring
B	Width of Clevis Support Section	J	Connector End Diameter
C	Length of Pin Reduced Section, Instrumented Zone	K	Distance Between Shear Planes
Dc	Bore Diameter	L	Overall Length of Pin
Dp	Nominal Pin Diameter	M	Anti-Rotation Plate - Rod End Clevis
E	Active Length of Pin	N	Height of Anti-Rotation Plate
Ec	Width of Rod End Clevis	Q	Anti-Rotation Plate - Clevis Pin
F	Clevis Pin Head Length	(◊)	Location of Strain Gage Installation
G	Clevis Support Section		

FEATURES OF STRAINERT LOAD SENSING CLEVIS PINS

- **EASY INSTALLATION:** By replacing pins in hydraulic cylinders with minimum alterations using custom keeper plates.
- **PRECISE LOAD SENSING:** Complete strain gage bridge circuit bonded and sealed inside small hole along longitudinal axis of Pin, by exclusive Strainert process.
- **RUGGED:** Due to self protecting nature of strain gage installation sealed in small hole. Proven immune to harsh environment.
- **ACCURACY:** Strainert Load Sensing Clevis Pins have combined error due to repeatability and non-linearity of less than 1% of rated load typically.

SPHC SERIES, STANDARD FORCE SENSING CLEVIS PINS FOR HYDRAULIC CYLINDERS

MODEL NO.	CYLINDER BORE DIAMETER	A	B	C	CE	D _P DIA.	EC	F	FL	G	H	J	K
SPHC-.5	1-1/2"	0.50	0.63	0.25	1.50	0.500	2.00	2.00	1.13	0.37	0.63	2.00	0.75
SPHC-.75	2" & 2-1/2"	0.94	0.72	0.31	2.38	0.750	2.75	2.00	1.88	0.47	0.44	2.00	1.25
SPHC-1	3-1/4"	1.19	0.84	0.31	3.13	1.000	3.25	2.00	2.25	0.60	0.44	2.00	1.50
SPHC-1.375	4"	1.56	1.16	0.44	4.13	1.375	4.38	2.00	3.00	0.78	0.50	2.00	2.00
SPHC-1.75	5"	2.00	1.38	0.50	4.50	1.750	5.38	2.00	3.13	1.00	0.56	2.25	2.50
SPHC-2	6"	1.94	1.35	0.56	5.50	2.000	5.38	2.00	3.50	0.97	0.56	2.50	2.50
SPHC-2.5	7"	2.38	1.56	0.63	6.50	2.500	6.38	2.00	4.00	1.18	0.63	3.00	3.00
SPHC-3	8"	2.31	1.53	0.69	6.75	3.000	6.38	2.00	4.25	1.16	0.63	3.50	3.00
SPHC-3.5	10"	3.13	2.19	0.88	8.50	3.500	8.63	2.00	5.69	1.55	0.63	4.00	4.00
SPHC-4	12"	3.50	2.38	1.00	10.00	4.000	9.63	2.25	6.44	1.75	0.63	4.50	4.50
SPHC-5	14"	4.88	3.06	1.13	12.75	5.000	12.63	2.25	7.94	2.43	0.63	5.50	6.00

MODEL NO.	CYLINDER BORE DIAMETER	L	MB	MR	N	P	Q	M	S	CW	CB	E	CAPACITY LBS.
SPHC-.5	1-1/2"	4.63	2.00	0.56	1.50	0.750	1.00	1.00	0.25	0.50	0.75	2.50	3,500
SPHC-.75	2" & 2-1/2"	5.19	2.50	1.06	1.75	0.750	1.50	1.50	0.25	0.63	1.25	3.50	6,000
SPHC-1	3-1/4"	5.69	3.00	1.13	2.50	0.750	1.50	2.00	0.25	0.75	1.50	4.50	16,500
SPHC-1.375	4"	6.88	3.40	1.75	2.88	1.130	1.50	2.75	0.38	1.00	2.00	5.00	25,000
SPHC-1.75	5"	7.94	4.30	1.88	3.25	1.130	1.50	3.50	0.38	1.25	2.50	6.50	39,000
SPHC-2	6"	7.94	5.50	2.13	3.50	1.130	2.00	4.50	0.38	1.25	2.50	7.50	56,000
SPHC-2.5	7"	9.00	6.50	2.50	4.00	1.130	2.50	5.00	0.38	1.50	3.00	8.50	77,000
SPHC-3	8"	9.00	7.00	2.75	4.50	1.130	3.00	5.50	0.38	1.50	3.00	9.50	100,000
SPHC-3.5	10"	11.25	9.50	3.50	5.00	1.880	3.50	7.00	0.63	2.00	4.00	12.63	157,000
SPHC-4	12"	12.50	10.50	4.00	5.50	1.880	4.00	8.00	0.63	2.25	4.50	14.88	226,000
SPHC-5	14"	15.50	11.50	4.50	6.50	1.880	5.00	10.00	0.63	3.00	6.00	17.25	300,000

ORDERING INFORMATION

SPHC-1 X O (SS)

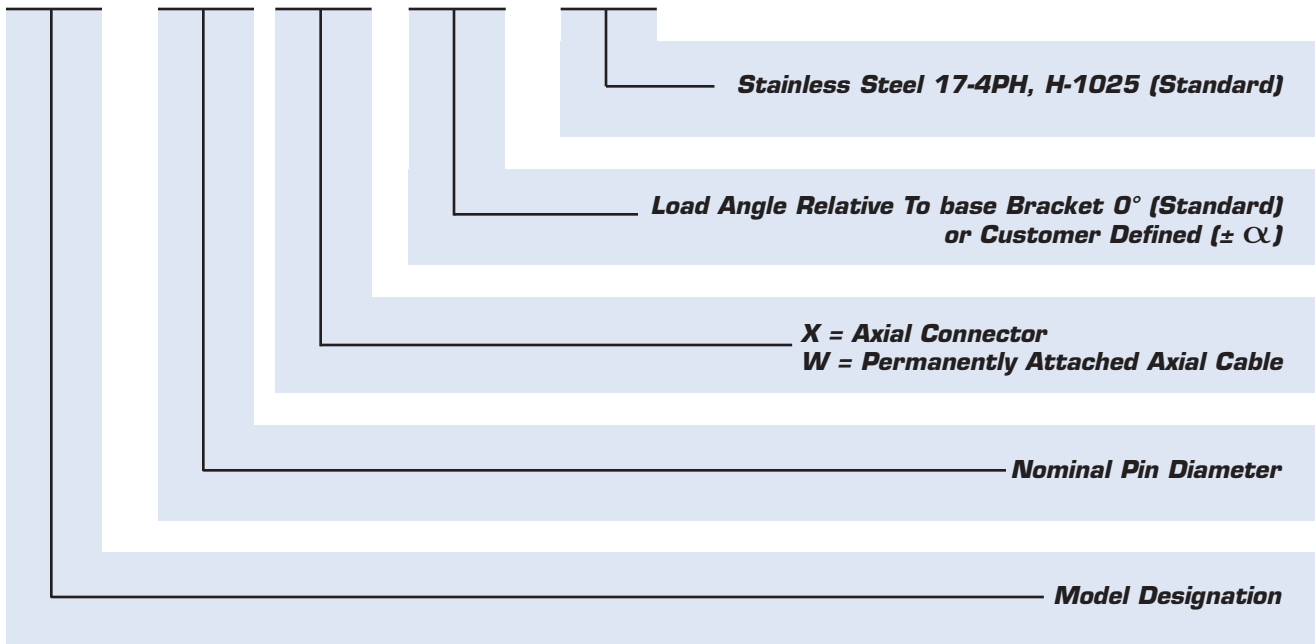

Standard Models include Modulus & Temperature Compensation, and Detailed Calibration Data (LO) (See Calibration Section).