

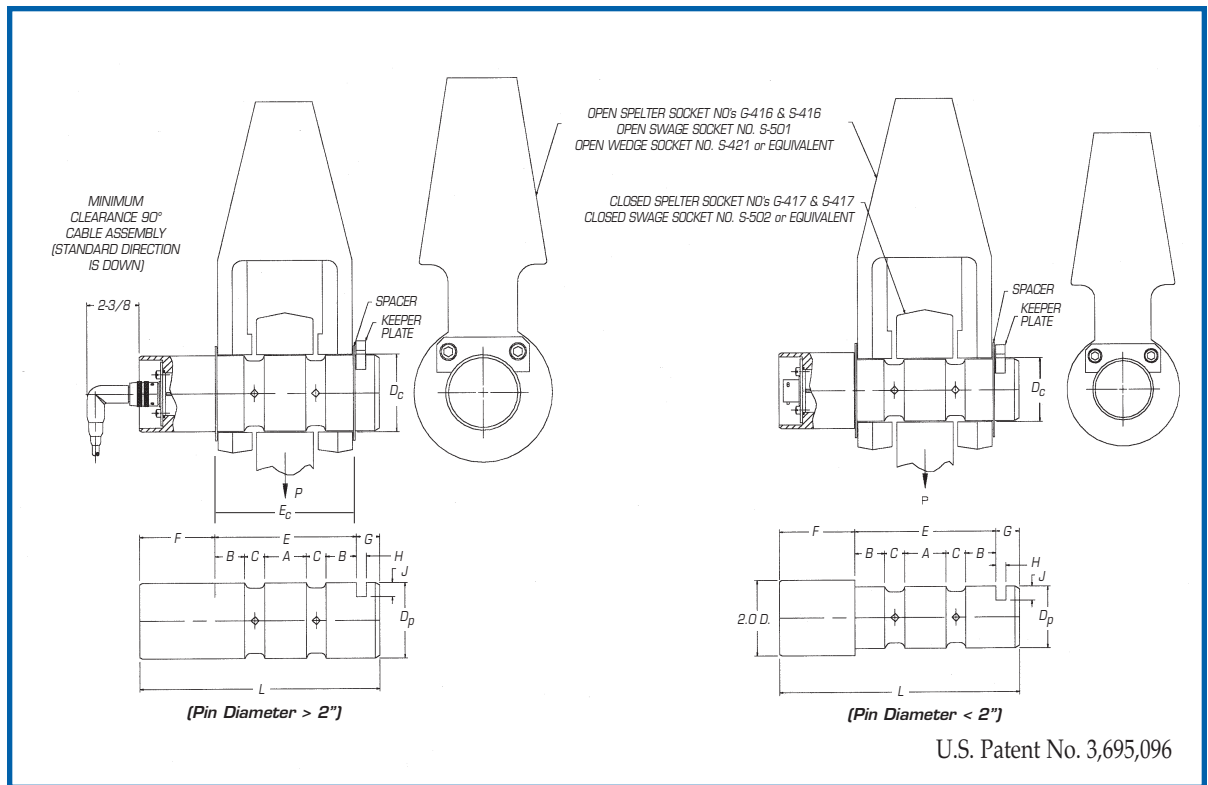

SPA Series, Standard Wire Rope Clevis Pins



NOMENCLATURE

A	Width of Center Loading Section	G	Extension of Pin for Keeper Plate Installation
B	Width of Clevis Support Section	H	Width of Keeper Plate Slot
C	Length of Pin Reduced Section, Instrumented Zone	J	Depth of Keeper Plate Slot
Dc	Socket Bore Diameter	L	Overall Length of Pin
Dp	Nominal Pin Diameter	P	Load Capacity
E	Active Length of Pin	U	Nominal Spacer Thickness (E-Ec) / 2
Ec	Width of Open Spelter Socket	↔	Location of Internal Strain Gage Installation
F	Clevis Pin Head Length		

FEATURES OF STRAINERT LOAD SENSING CLEVIS PINS

- **EASY INSTALLATION:** By replacing pins in Crosby (or Equivalent) wire rope socket, with minimum machining alterations (2-tapped holes), and hardware (2-bolts, keeper plate).
- **PRECISE CABLE LOAD SENSING:** Complete bridge circuit bonded and sealed inside small hole along longitudinal axis of Pin, calibrated in the direction of the applied load.
- **RUGGED:** Self protecting nature of strain gage installation sealed in small hole, and has proven to be immune to harsh environment.
- **ACCURACY:** Strainert Load Sensing Clevis Pins have combined error due to repeatability and non-linearity less than 1% of rated load typically.

TYPICAL LOAD SENSING APPLICATIONS

- End of Whip Line Winch
- Clam Shell
- Boom Pendant Cable Support
- Crane Hoist Cables
- Mooring Lines
- Bridge Support Cables
- Dead End of Winch Pulley System
- ...and any application where load indication on a wire rope clevis is required.

SPA SERIES, STANDARD WIRE ROPE CLEVIS PINS

MODEL NO.	WIRE ROPE DIA. IN.	P CAP. LBS.	A	B	C	Dp DIA.	E	F	G	H	J	L	U	WT. LBS.	SAFETY FACTOR	KEEPER PLATES
SPA-12.5	0.44 – 0.50	12,500	11/16	15/32	5/16	1.000	2-1/4	2	1/2	13/64	1/4	4-3/4	1/8	1.7	3.8	SPA-12.5-112-1-A
SPA-16	0.56–0.63	16,000	13/16	17/32	3/8	1.187	2-5/8	2	5/8	17/64	1/4	5-1/4	1/8	2.1	4.1	SPA-16-112-1-A
SPA-25	0.75	25,000	15/16	19/32	7/16	1.375	3	2	5/8	17/64	5/16	5-5/8	1/8	2.6	3.8	SPA-25-112-1-A
SPA-32	0.88	32,000	1-1/8	11/16	1/2	1.625	3-1/2	2	5/8	17/64	3/8	6-1/8	1/8	3.5	3.5	SPA-32-112-1-A
SPA-50	1.00	50,000	1-7/16	23/32	9/16	2.000	4	2	5/8	17/64	3/8	6-5/8	1/8	5.5	4.2	SPA-50-112-1-A
SPA-65	1.13	65,000	1-5/8	13/16	5/8	2.250	4-1/2	2	5/8	17/64	3/8	7-1/8	1/8	7.5	3.8	SPA-65-112-1-A
SPA-75	1.25–1.38	75,000	1-7/8	15/16	5/8	2.500	5	2	5/8	17/64	1/2	7-5/8	1/8	10.0	4.6	SPA-75-112-1-A
SPA-100	1.50	100,000	2	1-1/8	11/16	2.750	5-5/8	2	3/4	13/32	1/2	8-3/8	1/8	13.0	4.1	SPA-100-112-1-A
SPA-125	1.63	125,000	2-5/16	1-3/32	11/16	3.000	5-7/8	2	7/8	13/32	5/8	8-3/4	1/8	17.0	4.4	SPA-125-112-1-A
SPA-160	1.75–1.88	160,000	2-5/8	1-5/16	7/8	3.500	7	2	1	17/32	5/8	10	3/16	26.0	4.5	SPA-160-112-1-A
SPA-180	2.00–2.13	180,000	3	1-5/8	7/8	3.750	8	2	1	17/32	3/4	11	3/16	33.0	4.6	SPA-180-112-1-A
SPA-220	2.25–2.38	220,000	3-1/4	1-15/16	1	4.250	9-1/8	2-1/4	1-1/4	21/32	7/8	12-5/8	3/16	49.0	4.3	SPA-220-112-1-A
SPA-275	2.50–2.63	275,000	3-11/16	2-5/32	1-1/16	4.750	10-1/8	2-1/4	1-1/4	21/32	7/8	13-5/8	3/16	66.0	4.4	SPA-275-112-1-A
SPA-300	2.75–2.88	300,000	3-7/8	2-11/16	1-1/8	5.000	11-1/2	2-1/4	1-1/2	25/32	1	15-1/4	1/4	83.0	4.1	SPA-300-112-1-A
SPA-330	3.00–3.13	330,000	4-3/16	2-27/32	1-3/16	5.250	12-1/4	2-1/4	1-1/2	25/32	1	16	1/4	95.0	4.0	SPA-330-112-1-A
SPA-360	3.25–3.38	360,000	4-1/2	3	1-1/4	5.500	13	2-1/4	1-3/4	25/32	1-1/8	17	1/4	110.0	3.9	SPA-360-112-1-A
SPA-400	3.50–3.63	400,000	4-5/8	3-3/16	1-3/8	6.000	13-3/4	2-1/4	1-3/4	25/32	1-1/8	17-3/4	1/4	155.0	4.1	SPA-400-112-1-A
SPA-600	3.75–4.00	600,000	5-3/8	3-3/16	1-5/8	7.000	15	2-1/4	1-3/4	25/32	1-1/4	19	1/4	200.0	4.4	SPA-600-112-1-A

ORDERING INFORMATION

SPA-100 (SS) X

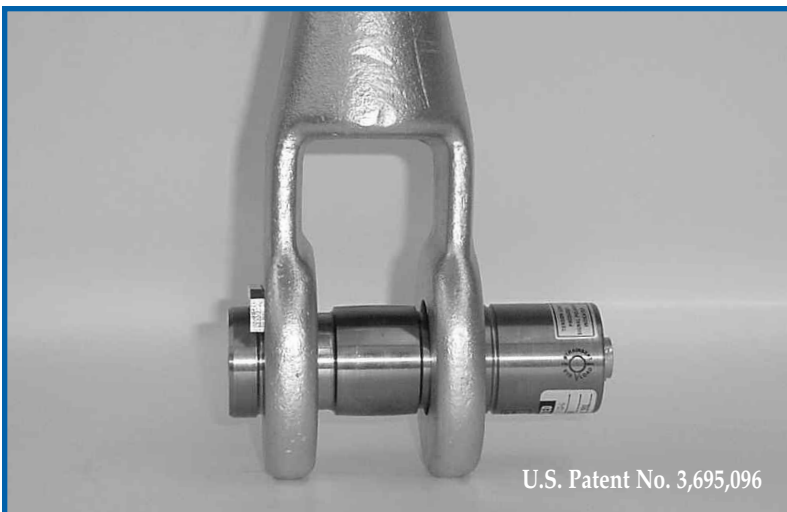
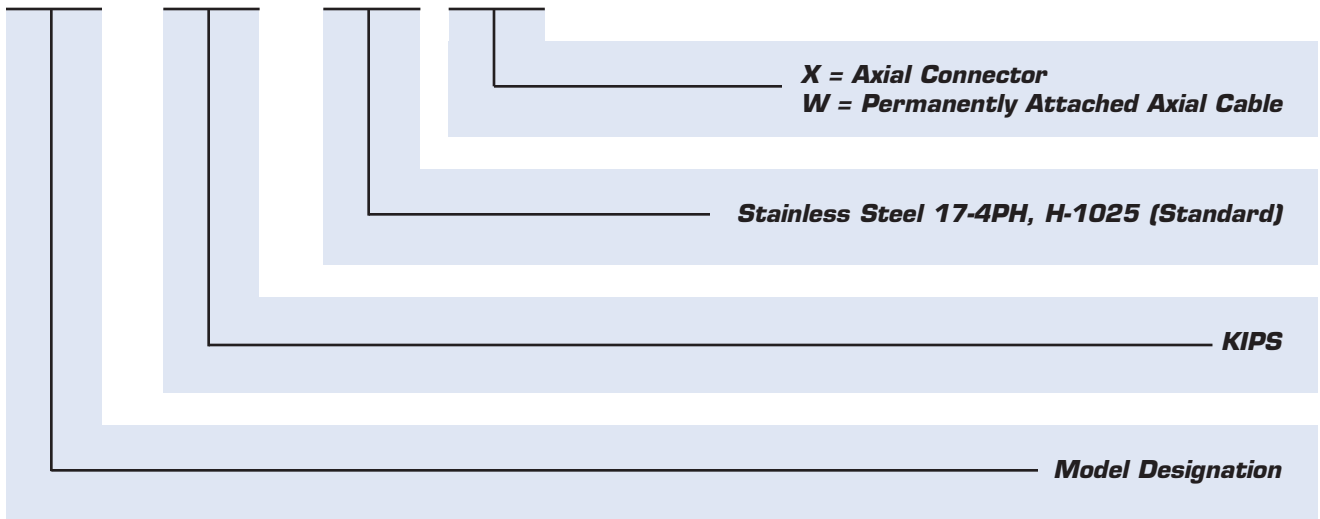

U.S. Patent No. 3,695,096

Standard Models include Modulus & Temperature Compensation, and Detailed Calibration Data (LO) (See Calibration Section) up to 500,000-lbs. Higher capacity Calibration Data is available at an additional charge, consult factory.