

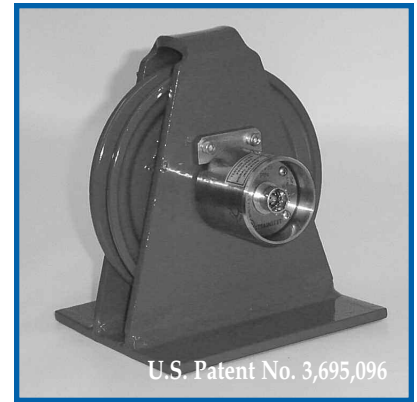

Strainert Instrumented Clevis Pins for Sheave Applications

Many Strainert Instrumented Clevis Pin designs are incorporated into sheave and pulley systems. The user has the option of either designing a sheave around our standard CPA Clevis Pin series or having a custom pin manufactured for an existing sheave design with a tailored measurement capacity and geometry, allowing for simple installation and optimized measurement capability.

The Instrumented Sheave Pins are often used to measure line tension by monitoring the reaction load on the pin. Using the equations provided below, the line tension can be determined.



CONSTANT WRAP ANGLE:

For a sheave with a constant wrap angle, the resultant load can be oriented in relation to a single force sensing axis and the following equations apply.

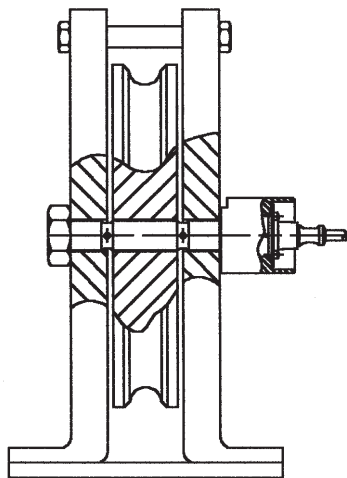

- **Axis of Maximum Sensitivity:**
Align Keeper Flat of Load Sensing Pin perpendicular to Axis of Maximum Sensitivity which is at one half the wrap angle

For this example, wrap angle $\emptyset = 105^\circ$
and $\emptyset/2 = 105^\circ/2 = 52.5^\circ$

\emptyset = Wrap Angle
T = Line Tension
P = Resultant Force on Sheave Pin

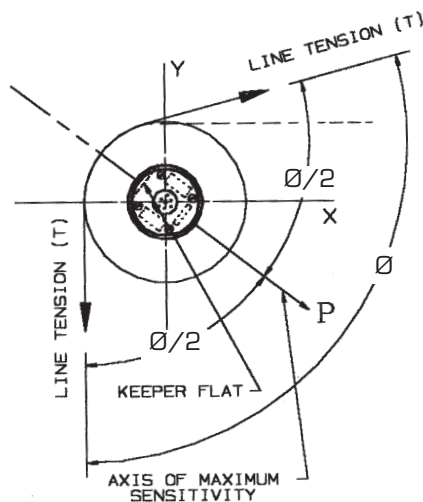

- **Line Tension (T):** To measure the tension in a line by measuring the reaction force on the sheave use the diagram and formulas provided below:

$$P = 2T \cos (\emptyset/2) \quad T = \frac{P}{2 \cos (\emptyset/2)}$$

Example: For a Wrap Angle of $\emptyset = 105^\circ$ and measured sheave load of 10,000-lbs. The Line Tension (T) can be determined by:

$$T = \frac{10,000}{2 \cos (52.5)} \quad T = 8,213\text{-lbs}$$

Strainert Instrumented Clevis Pins for Sheave Applications

VARIABLE WRAP ANGLE:

For a Sheave with a varying wrap angle, the force direction varies with respect to the force sensing axis. To address varying wrap angle applications, an instrumented pin with two sensing axes oriented 90° apart, measure the orthogonal X and Y loads. The X and Y outputs can then be used to resolve the magnitude and direction of the Sheave force on the pin, as well as the line tension. The following equations apply for a biaxial sheave pin with a variable wrap angle.

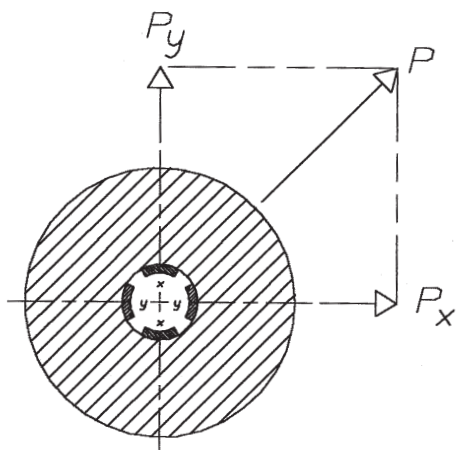

The cross section of the bi-axial clevis pin illustrates gage alignment. The gages marked Y will sense load component P_y , while the gages marked X will sense loads in the P_x direction. Given the outputs from the two bridges as E_x and E_y , and constants (K_x, K_y) , derived from calibration data*, the resultant force P is determined by:

$$P_x = K_x E_x \quad P_y = K_y E_y$$

$$\text{and Resultant Force } P = \sqrt{(P_x)^2 + (P_y)^2}$$

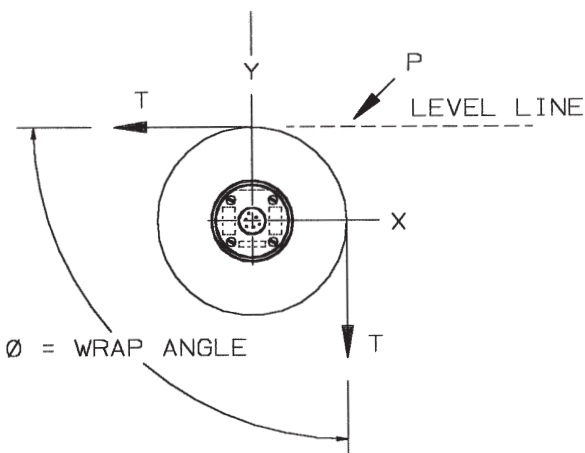

The Line Tension (T) and Wrap Angle (\emptyset) can be determined by:

$$T = \frac{P_x^2 + P_y^2}{2P_x}$$

$$\emptyset = 2\cos^{-1} \frac{P}{2T}$$

*Where P , P_x , and P_y are adjusted for cross-talk effects.

Note: For further discussion of Bi-Axial Clevis Pins see page 23 under Clevis Pin Optional Features.

Pin Design: For quotations on custom sheave pin designs, complete the "STRAINERT SHEAVE PIN QUESTIONNAIRE" presented on the following pages. Include additional drawings, comments, or special requirements as applicable.