



CPA/CBA Series, Standard Force Sensing Clevis Pins/Bolts

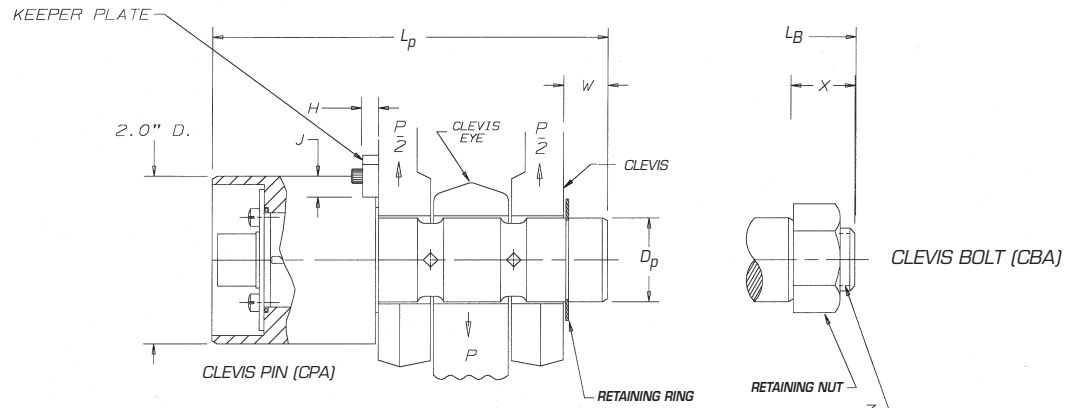

Figure 1
(Pin Diameter < 2")

MINIMUM
CLEARANCE
90° CABLE
ASSEMBLY
(STANDARD DIRECTION IS DOWN)

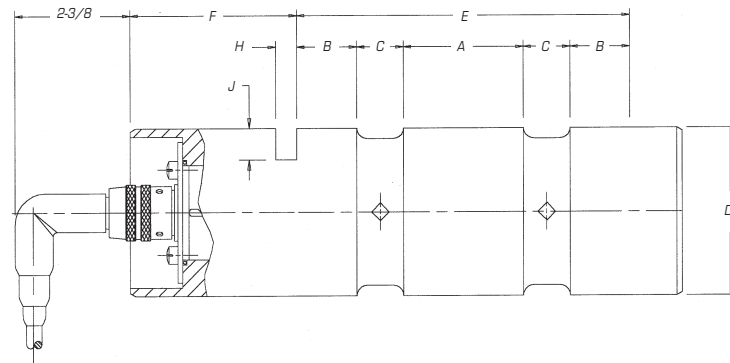

Figure 2
(Pin Diameter > 2")

U.S. Patent No. 3,695,096

NOMENCLATURE

A	Width of Center Loading Section	J	Depth of Keeper Plate Slot
B	Width of Clevis Support Section	L_B	Overall Length of Bolt (CBA Series)
C	Length of Pin/Bolt Reduced Section, Instrumented Zone	L_p	Overall Length of Pin
D_c	Clevis Bore Diameter, Eye Bore Diameter	P	Load Capacity
D_p	Nominal Pin/Bolt Diameter	W	Allowance for Retaining Ring Installation
E	Active Length of Pin/Bolt	X	Thread Length
F	Clevis Pin/Bolt Head Length	(◄)	Location of Internal Strain Gage Installation
H	Width of Keeper Plate Slot	Z	Thread Size (CBA Series)

FEATURES

- Precision Load Sensing
- Easy Installation
- Rugged
- Bolt Series, CBA
- Direct Force Measurement
- Internally Sealed Strain Gages
- High Strength Stainless Steel

CPA/CBA SERIES, STANDARD FORCE SENSING CLEVIS PINS/BOLTS

MODEL NO.	P CAPACITY LBS.	A	B	C	Dp DIA.	E	F	H	J	Lp	Lg	W	X	Z	KEEPER PLATES
CPA-0.375-1	1,500	3/8	5/16	3/16	0.375	1-3/8	2	13/64	1/4	3-11/16	3-3/4	5/16	3/8	5/16-24UNF	SPA-12.5-112-1-A
CPA-0.5-1	3,000	1/2	3/8	1/4	0.500	1-3/4	2	13/64	1/4	4	4-1/4	1/4	1/2	3/8-24UNF	SPA-12.5-112-1-A
CPA-0.75-1	6,000	11/16	7/16	5/16	0.750	2-3/16	2	13/64	1/4	4-1/2	4-7/8	5/16	11/16	1/2-20UNF	SPA-12.5-112-1-A
CPA-1	12,500	11/16	15/32	5/16	1.000	2-1/4	2	13/64	1/4	4-3/4	5	1/2	3/4	3/4-16UNF	SPA-12.5-112-1-A
CPA-1.25	18,000	1	5/8	3/8	1.250	3	2	17/64	1/4	5-5/8	5-7/8	5/8	7/8	1-14UNF	SPA-16-112-1-A
CPA-1.5	30,000	1-1/8	11/16	1/2	1.500	3-1/2	2	17/64	1/4	6-1/8	6-1/2	5/8	1	1-1/4-12UNF	SPA-25-112-1-A
CPA-2	50,000	1-7/16	23/32	9/16	2.000	4	2	17/64	3/8	6-5/8	7	5/8	1	1-1/2-12UN	SPA-50-112-1-A
CPA-2.5	75,000	1-7/8	15/16	5/8	2.500	5	2	17/64	1/2	7-5/8	8	5/8	1	1-3/4-16UN	SPA-75-112-1-A
CPA-2.75	100,000	2	1-1/8	11/16	2.750	5-5/8	2	13/32	1/2	8-3/8	8-3/4	3/4	1-1/8	2-12UN	SPA-100-112-1-A
CPA-3	125,000	2-5/16	1-3/32	11/16	3.000	5-7/8	2	13/32	5/8	8-3/4	9	7/8	1-1/8	2-1/4-12UN	SPA-125-112-1-A
CPA-3.5	160,000	2-5/8	1-5/16	7/8	3.500	7	2	17/32	5/8	10	10-1/4	1	1-1/4	2-1/2-12UN	SPA-160-112-1-A
CPA-4	200,000	3	1-3/4	1	4.000	8-1/2	2	17/32	3/4	11-3/4	12	1-1/4	1-1/2	2-3/4-12UN	SPA-200-112-1-A
CPA-5	300,000	3-7/8	2-11/16	1-1/8	5.000	11-1/2	2-1/4	25/32	1	15-1/4	15-1/4	1-1/2	1-1/2	3-12UN	SPA-300-112-1-A
CPA-6	400,000	4-5/8	3-3/16	1-3/8	6.000	13-3/4	2-1/4	25/32	1-1/8	17-3/4	-	1-3/4	-	-	SPA-400-112-1-A
CPA-7	600,000	5-3/8	3-3/16	1-5/8	7.000	15	2-1/4	25/32	1-1/4	19	-	1-3/4	-	-	SPA-600-112-1-A
CPA-8	800,000	6-1/4	3-1/2	1-3/4	8.000	16-3/4	2-1/4	25/32	1-3/8	20-3/4	-	1-3/4	-	-	SPA-600-112-1-A

ORDERING INFORMATION

CPA-2.5 (SS) X

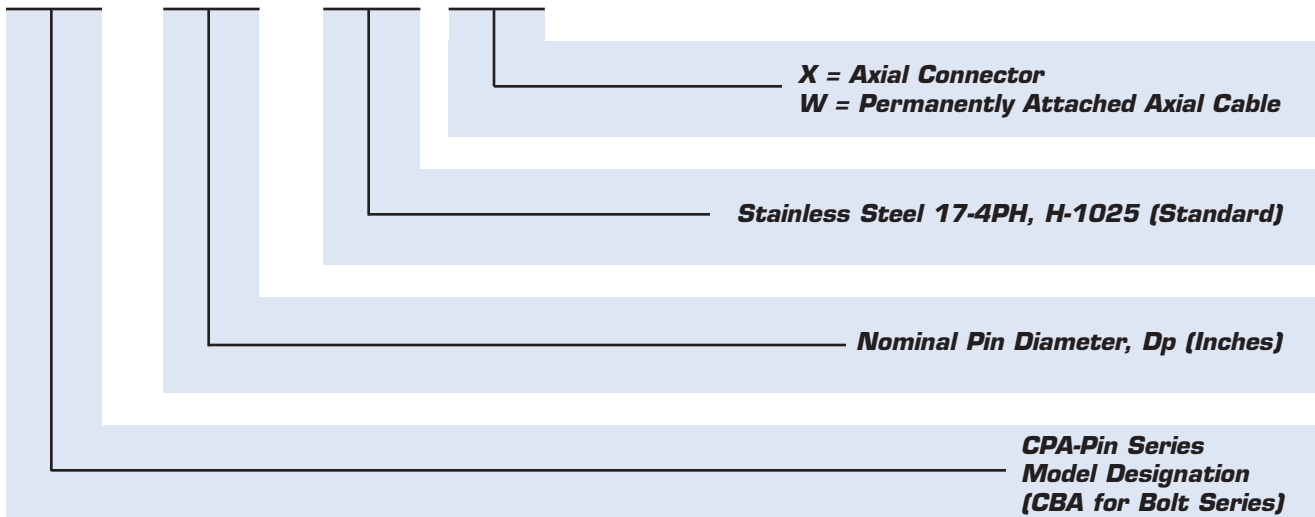

Standard Models include Modulus & Temperature Compensation, and Detailed Calibration Data (LO) (See Calibration Section) up to 500,000-lbs. Higher capacity Calibration Data is available at an additional charge, consult factory.